

Instructions for use
—Type 2 COMPACT

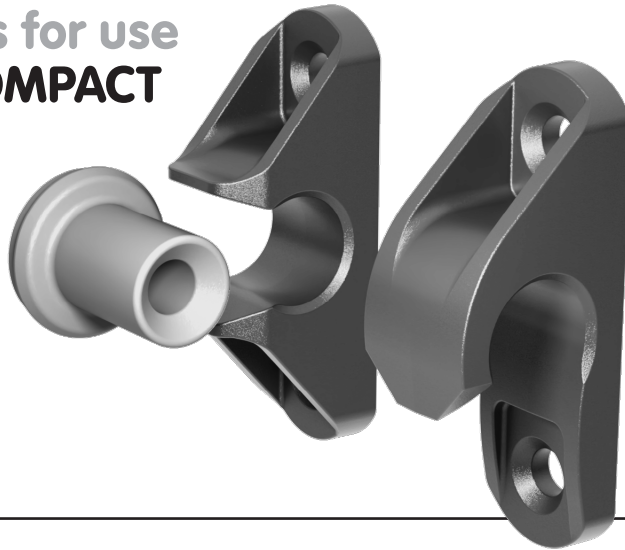

Type 2 COMPACT button-fix

The Button-fix concept is simple: durable Buttons are attached to the background structure and the mating Fixes are attached to the removable panel. Bring them together and push until they ‘click’.

The Type 2 COMPACT range is moulded in nylon and acetal. They securely connect panels at 90°, overlapping panels or panels to a frame, with either a simple push-on or a drop-down engagement, as required. Type 2 COMPACT can be used for hanging a wide variety of wall and ceiling panels.

Visit the website for more information on the complete Button-fix range, including videos of the Type 2 COMPACT in use and CAD downloads. You can also obtain a new copy of these instructions from the website in the event of loss or in the event that Buttonfix modifies the instructions.

Buttonfix Limited retains the right to modify the instructions as it deems appropriate and the consumer is responsible for checking the website for the latest information.

Warnings

—Button-fix is intended for furniture construction and interior fittings and is not intended, nor should it be used, for any other purpose.

—**WARNING:** Serious damage to property and severe bodily injury can result from (1) improper use, application or installation of the Button-fix or (2) use as part of improperly designed or constructed assemblies or materials.

—Provided that the screws and substrate are properly matched, and all other instructions complied with, independent tests showed that a vertical panel fixed with four Type 2 COMPACT Push-on Fixes can support loads weighing up to a maximum of 60kg (132 lbs).

Four Type 2 COMPACT Drop-down Fixes can support up to 120kg (265 lbs) on a vertical panel, and also up to 20kg (44 lbs) in ceiling orientation. For critical applications it is essential to perform your own tests.

—Each Type 2 COMPACT Push-on Fix requires approximately 20kg (44 lbs) of force to engage and separate the Button and Fix; this should be taken into account when designing your installation and defining your safety factors.

—Avoid any contact with aggressive solvents and cleaning products.

—It is not possible for Buttonfix to warn the consumer about every possible danger related to use of the Button-fix and the consumer must use his or her own good judgment when installing and using Button-fix.

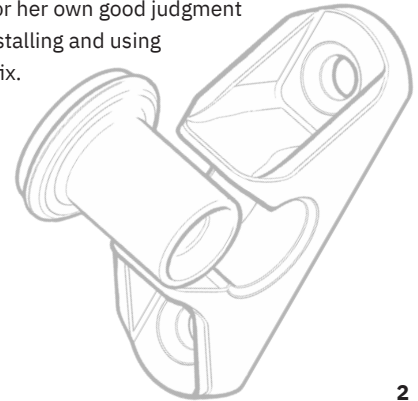

The fix

Type 2 COMPACT Button-fix connects panels at 90°, overlapping panels or panels to a frame. There are two options available: one with a straight push on/pull off engagement and one with a drop-down engagement. Both Fixes use the same Fix marker accessory, and have the same screw-fixing centres. On internal panels, they can be mixed to create a pivoting access panel.

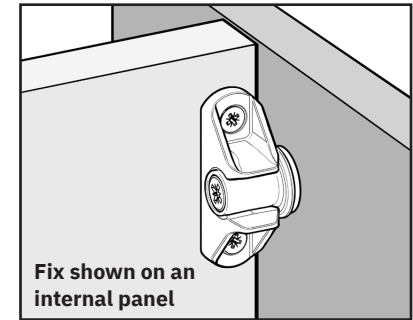
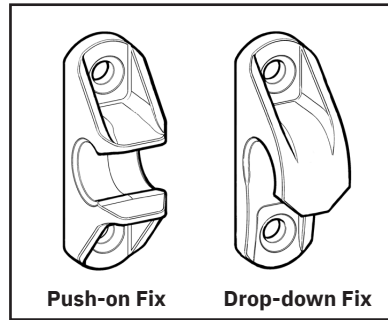

1. Push-On Fix

The Push-on Fix is ideal for panels that need to be easily removable, for example, to access electrical or plumbing services behind. They also suit installations where there is no clearance above the panel and Drop-down Fixes cannot be used.

The Push-on Fix is for vertical panels only. It should never be used for ceiling panel applications, or installations where the weight of the panel acts to disengage the Button-fix.

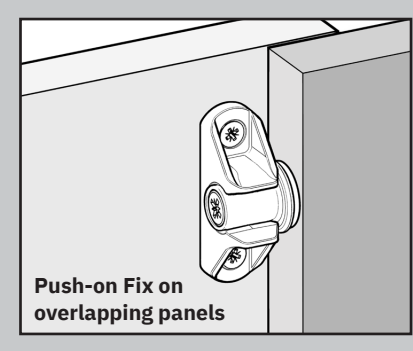
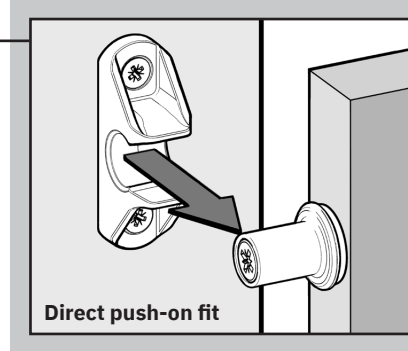

2. Drop-Down Fix

The Drop-down Fix offers greater security than the Push-on Fix. It is ideal for mounting high-level panels and panels carrying cantilevered loads. It requires a 15mm 'drop-down' gap to fit or remove the panel.

The Drop-down Fix can be used in angled or horizontal applications, not suited to Push-on Fixes. For example, they can be used on ceiling panels or access panels below wheelchair-accessible washstands.*

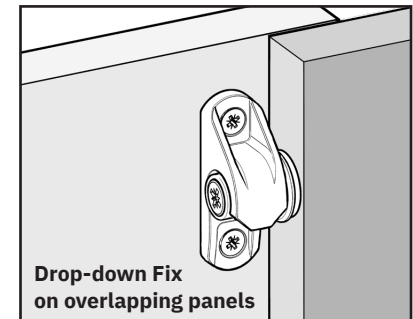
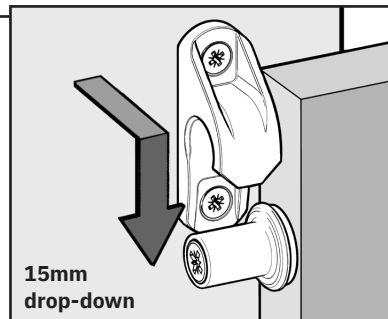

* compliant with the Americans with Disabilities (ADA) regulations

The button

The Type 2 COMPACT Button is designed to fit to the edge of a stud frame or an 18mm panel behind the removable panel. The Button centre has a backset of only 9mm. When attaching to the edge of an 18mm panel, first drill a pilot hole to suit the screw.

Use $\varnothing 5\text{mm}$ or #10 countersunk screws with a length of at least 35mm (see screw fixing guide on page 6).

Fix marker accessory

The Fix marker accessory helps to mark out where to install the Buttons and Fixes, without the need for measurement.

The Fix marker is clipped onto the Button, then positioned on the stud or background panel. The Button is then screwed in place. For edge-fixing into 18mm panels we recommend marking out and drilling a pilot hole, particularly on MDF or MFC.

After attaching all the Buttons, and with the Fix markers still connected, carefully align the front panel then press firmly against the marker spikes. The markers will leave indents in the panel surface, which can be used as guides for positioning the Fixes. On surfaces that don't easily show marks, such as heavily textured or rough surfaces, apply a layer of masking tape or Gaffer tape, which will show the indents more clearly.

The Fix markers can be re-used to mark out the next panel.

Please note that Fix marker accessories need to be ordered separately from the Button-fixes.

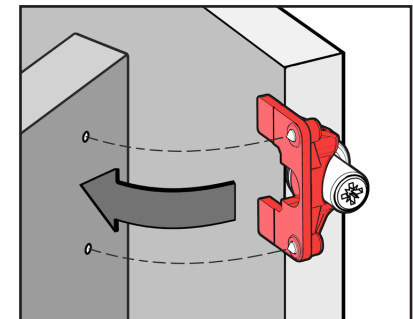
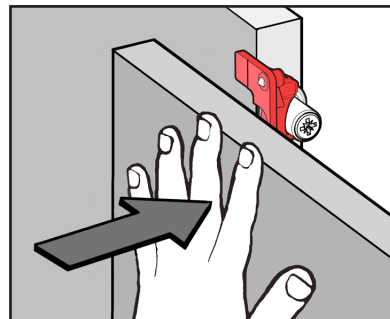
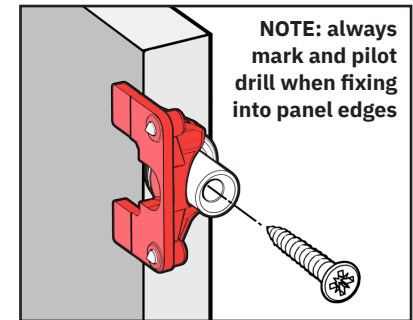
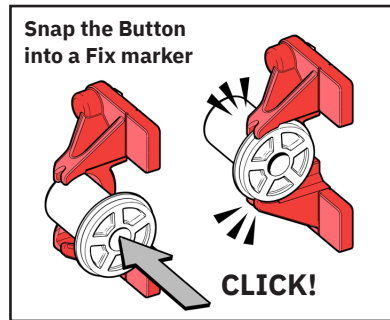
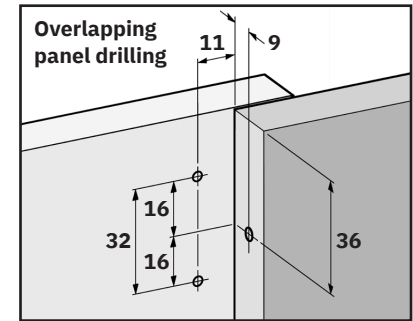
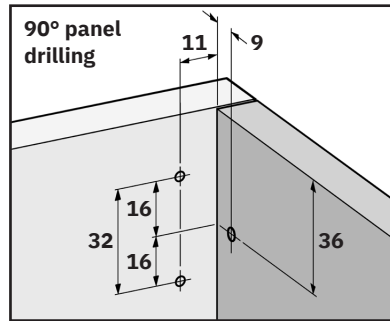

Suggested layout and loading guide

—**Wall Panels:** As an approximate guide, we suggest that Button-fix centres are no greater than 600mm apart.

Four Type 2 COMPACT Push-on Button-fixes can support a wall panel of up to 60kg for vertical panels* with no cantilever loads.

Four Type 2 COMPACT Drop-down Button-fixes can support a wall panel of up to 120kg in normal conditions. It can carry cantilever loads, provided the cantilever projection is less than or equal to the height of the supporting panel.

—**Ceiling Panels:** As an approximate guide, we suggest that Button-fix centres are no greater than 400mm apart.

Four Type 2 COMPACT Drop-down Button-fixes can support a ceiling panel of up to 20kg. As a general rule, allow for a maximum loading of **5kg per Fix**. **Push-on Fixes should not be used in ceiling panel applications.**

Ensure ceiling panels are locked, or restrained by adjacent panels, to prevent accidental disengagement due to shock loads, knocks or vibration.

***IMPORTANT:** Any panel that is not vertical and is inclined, should be fixed using Drop-down Fixes only.

Safety cords/chains

For critical applications, such as large panels in public areas, ceiling panels and in maritime/transport interiors, always use safety cords or chains. They should be specified to accommodate the load of the particular panel.

Typical wall panel layout

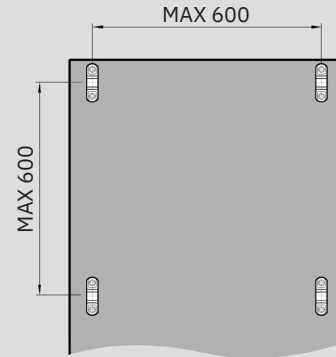

FOR CRITICAL APPLICATIONS USING PUSH-ON FIXES, USE SAFETY CORDS AT THE TOP CORNERS

Typical ceiling panel layout: USE DROP-DOWN FIXES ONLY

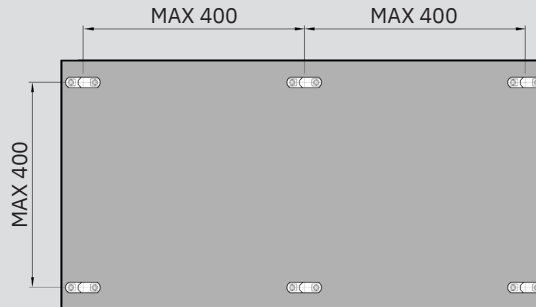

ENSURE CEILING PANELS CANNOT DISENGAGE ACCIDENTALLY DUE TO SHOCK LOADS, KNOCKS OR VIBRATION

FOR CRITICAL APPLICATIONS USE SAFETY CORDS AT EACH CORNER



Load guide: maximum 5kg per Fix for ceiling panels

Screw fixings guide

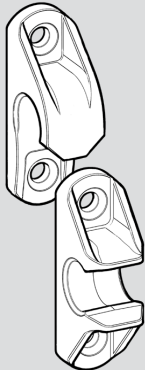
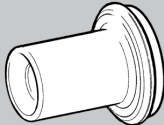
Product/configuration	Panel thickness/ material	Screw type	net thread length	Notes
Drop-down and Push-on Fix 	8 to 12mm thick Plastic, HPL, SGL Plywood, MDF, MFC	#8.16 × 0.375" flange head Plas-60	5.7mm	Sales@intafast.com Pilot drill Ø3mm in soft materials; Ø3.8mm in HPL and hard plastics
		#8 (4.2mm) × 0.375" (9.5mm) flange head PZ self-tapping	5.7mm	Accu.co.uk (product code: SPBFT-No.8-3/8-A2) A2 stainless steel
		#8 × 0.5" (12.7mm) flange head Easydrive PZ self-tapping	9.4mm	Screwfix.com (product code: 8979H) Add M5 × 1mm thick washer under head for 10mm material. Pilot drill Ø3mm in MDF; Ø3.8mm in HPL, SGL and hard plastics
		Ø3.5 × 12mm CSK Timco	8.7mm	Screwfix.com (product code: 961KG)
		M4 CSK/pan head machine screws		User-defined lengths
	greater than 12mm Plywood, MDF, MFC	Ø4.0 × 16 CSK (#8 × 0.625") Ø4.5 × 16 CSK (#9 × 0.625")	11.5mm	
		Ø4.0 × 20 CSK (#8 × 0.75") Ø4.5 × 20 CSK (#9 × 0.75")	15.5mm	
		#8 × 0.75" (18mm) flange head Easydrive PZ self-tapping	15.3mm	Screwfix.com (product code: 6553H) Pilot drill Ø3mm in MDF
Button 	Edge-fixed or face-fixed 18mm Plywood, MDF, MFC	Ø4.5 × 35mm CSK Ø5 × 35mm CSK	15mm	Pilot drill Ø3.2mm when edge-fixing
		#8 × 1.375" CSK #10 × 1.375" CSK	15mm	Pilot drill Ø3.2mm when edge-fixing
	M5 CSK machine screw		User-defined lengths	

Suggestions are based on screws available in the UK. Screws from other suppliers may also be suitable but have not been validated by Buttonfix Limited—**always perform your own tests for critical applications.**

Specifications

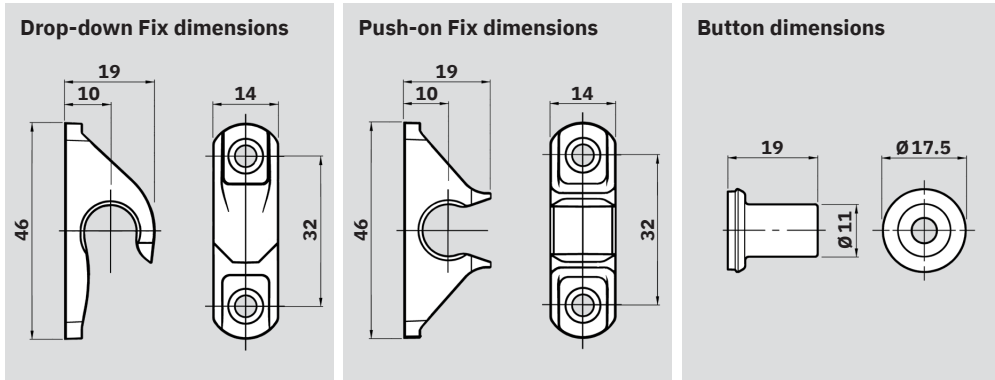

Material: Nylon PA6, 30% glass filled (Button & Drop-down Fix) and Acetal (Push-on Fix)

Maximum load advice: Wall panels with 4 x Drop-down Fixes = 120 kg
Wall panels with 4 x Push-on Fixes = 60 kg

Ceiling panels with 4 x Drop-down Fixes = 20 kg
Never use Push-on Fixes on ceiling panels

—Advice on panel loads is given with the proviso that the screws and substrate are properly matched, and all other instructions complied with. For critical applications it is essential to perform your own tests.

—Disengagement force for a single Type 2 COMPACT Push-on Fix is approximately 20 kg

Origin: Manufactured in the UK

Buttonfix Limited
Unit A, 1 Britton Street
London, EC1M 5NW

T: +44 (0)20 8150 7190

E: info@button-fix.com

EU Authorised Representative:

AR Experts BV
Boeingavenue 209
1119PD Schiphol-Rijk
The Netherlands

button-fix.com